

FEATURES

- 37 mm dial size.
- Polycarbonate lens.
- Stainless steel case.
- Phosphor bronze spiral tube.
- 1/8" NPT Bronze back connection.
- Accuracy up to $\pm 4\%$ Full scale.



APPLICATIONS

- Extinguisher equipment.

OPERATING SPECIFICATIONS

1. Working temperature
-20°C to 60°C.

	MODELS	SPECIFICATIONS
Case	All models	Stainless steel
Lens	All models	Polycarbonate
Connection	All models	1/8" NPT Bronze
Movement	All models	Phosphor bronze
Accuracy	All models	Working pressure $\pm 4\%$
Pointer	All models	Aluminum
Dial	All models	Aluminum, scale in MPa Designed according to NOM-045-SCFI.

* SPECIAL REQUEST

Please contact factory for special dial artwork and ranges.

ORDERING INFORMATION

SERIES	XT
SIZE	37mm
CASE	Aluminum
PRESSURE RANGES	1.2 MPa 0 to 1.2 MPa 1.7 MPa 0 to 1.7 MPa
EXAMPLE	<ul style="list-style-type: none"> Select series.....XT Select pressure range and scale option.....1.7 XT-1.7

OUTLINE DIMENSIONS

XT1.2

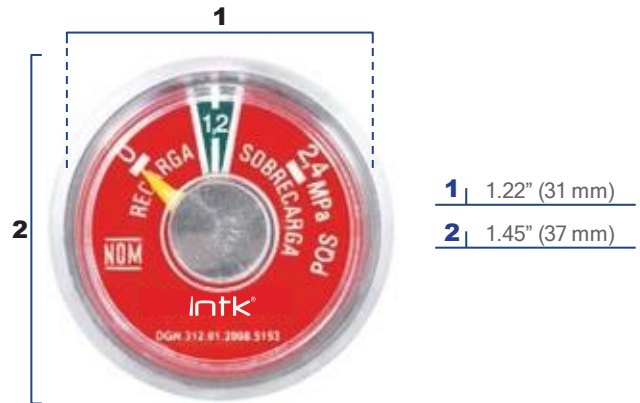
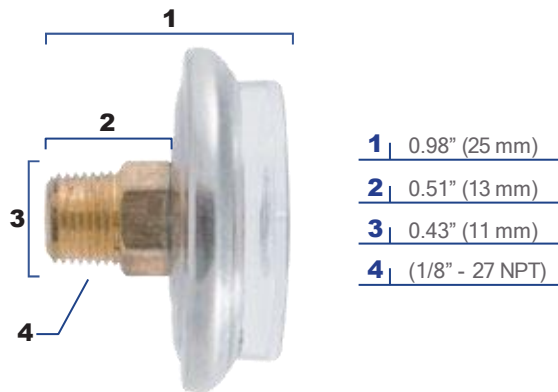

XT1.7

